



Research Engineering & Manufacturing Inc.
55 Hammarlund Way Tech II
Middletown, RI, 02842, U.S.A.
Tel: (401) 841-8880 • Fax: (401) 841-5008
Website: www.taptite.com
E-mail: reminc@reminc.net

CONTI Fasteners AG
Albisstrasse 15
CH-6340 Baar, Switzerland
Tel: 41 41 761 58 22 • Fax: 41 41 761 3018
Website: www.taptite.com
E-mail: conti@contifasteners.ch

REMINC/CONTI TAPTITE PRO® SCREWS END-USER SPECIFICATIONS

PR-183
November 2018

The World's Leading Fastener Manufacturers are TAPTITE 2000® Licensees
The following are some of the trademarks licensed by REMINC:
TAPTITE® PRO™ TAPTITE®, TAPTITE II®, TYPE-TT®, DUO-TAPTITE®, CORFLEX®, PLASTITE® POWERLOK®,
EXTRUDE-TITE®, KLEERLOK®, FASTITE®, TAPTITE 2000®, TYPE TT 2000®, TAPTITE 2K®, TYPE TT 2K®

REMINC/CONTI
TAPTITE PRO® SCREWS
END-USER SPECIFICATIONS

INTRODUCTION

This document provides end-users of TAPTITE PRO® screws dimensional and material information to be used as a uniform standard for TAPTITE PRO® screws. End-users may use this copyrighted material to create their own in-house TAPTITE PRO® standards. This information is intended for use only with TAPTITE PRO® and other genuine TAPTITE® products and prior notification to and permission from REMINC/CONTI is required before incorporating this copyrighted material into any company documents.

SCOPE

- ✧ TAPTITE PRO® screws are high performance thread rolling (forming) screws which form internal threads in nut members, eliminating the need for pre-tapping the nut member, thus lowering the in-place cost of assembly. TAPTITE PRO® screws provide an improved level of overall performance over previous TAPTITE® designs. TAPTITE PRO® screws are characterized by having a unique or multiple TRILOBULAR™ configuration and a unique parabolic thread form.
- ✧ Standard TAPTITE PRO® screws have two general configurations. Screws MP5 and smaller have a four-thread tapered lead with a unique optimum TRILOBULAR™ configuration. Standard TAPTITE PRO® screws MP6 and larger two stabilizing threads which align the screw in the hole and three tapered threads and multiple TRILOBULAR™ geometry.
- ✧ TAPTITE PRO® screws are available with three different heat treatments to suit various nut member materials.
- ✧ Standard TAPTITE PRO® screws, MP5 and smaller, are case hardened for use in steel applications.
- ✧ Standard TAPTITE PRO® screws, MP6 and larger, are supplied with CORFLEX®-I™ heat treatment which provides a neutral hardened screw to any specified grade strength level with a selectively hardened point for thread forming into steel nut members.
- ✧ Although CORFLEX®-I™ heat treatment is recommended for MP6 and larger sizes, TAPTITE PRO® screws of any size can be supplied case hardened. Case hardened screws, MP6 & larger are not recommended for structural applications.
- ✧ TAPTITE PRO® screws, of any size, which are to be used in soft metals such as aluminum, zinc or magnesium can be heat treated as CORFLEX®-N™ screws. This heat treatment is basically neutral hardening to achieve the desired grade strength level.
- ✧ TAPTITE PRO® SP™ screws have a short point suitable for use in blind holes in aluminum, zinc and magnesium and are supplied with CORFLEX®-N™ heat treatment.
- ✧ TAPTITE PRO® CA™ screws can be supplied with a cut-off or non-cut-off style point. These screws are used when there are alignment problems, and they can be supplied with the same heat treatment as standard TAPTITE PRO® screws dependent on the various nut member materials.
- ✧ All TAPTITE PRO® screws can be supplied with standard coatings and lubricants.

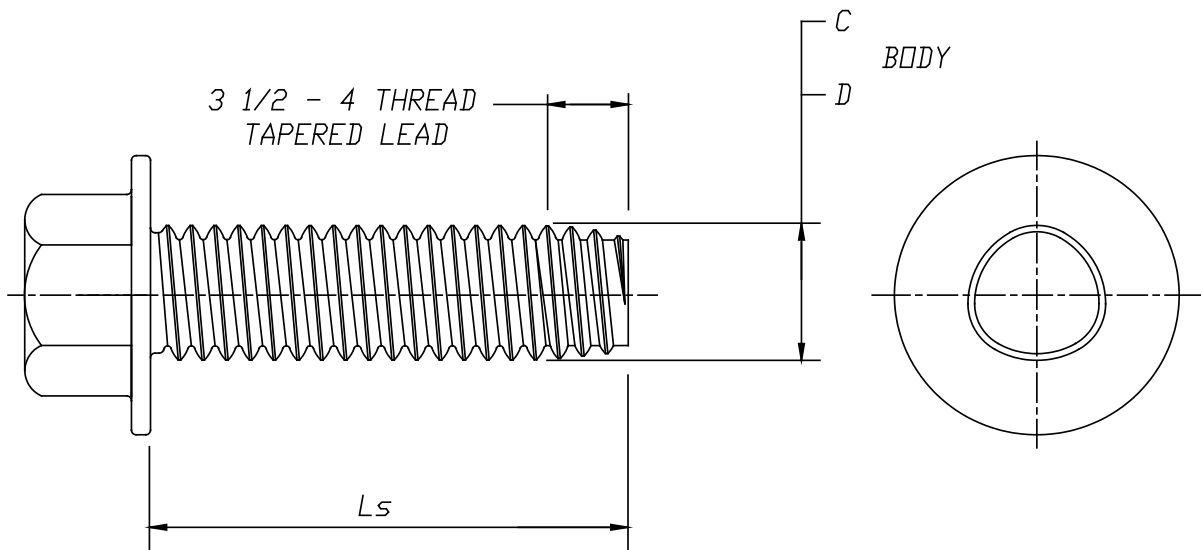

SIZE	PITCH	LIMITS	C	D
MP1.0	0.25	Max	1.000	0.975
		Min	0.955	0.924
MP1.2	0.25	Max	1.200	1.175
		Min	1.155	1.124
MP1.4	0.30	Max	1.405	1.375
		Min	1.355	1.317
MP1.6	0.35	Max	1.61	1.58
		Min	1.53	1.49
MP1.8	0.35	Max	1.81	1.78
		Min	1.73	1.69
MP2.0	0.40	Max	2.01	1.97
		Min	1.93	1.88
MP2.2	0.45	Max	2.21	2.17
		Min	2.12	2.06
MP2.5	0.45	Max	2.52	2.48
		Min	2.43	2.37
MP3.0	0.50	Max	3.02	2.97
		Min	2.93	2.87
MP3.5	0.60	Max	3.52	3.46
		Min	3.42	3.35
MP4.0	0.70	Max	4.02	3.95
		Min	3.92	3.83
MP4.5	0.75	Max	4.52	4.45
		Min	4.41	4.32
MP5.0	0.80	Max	5.02	4.94
		Min	4.91	4.81

Notes: Ls = Screw length ordered.
Tolerance per customer requirements or licensee practice.
Dimensions shown are before plate.

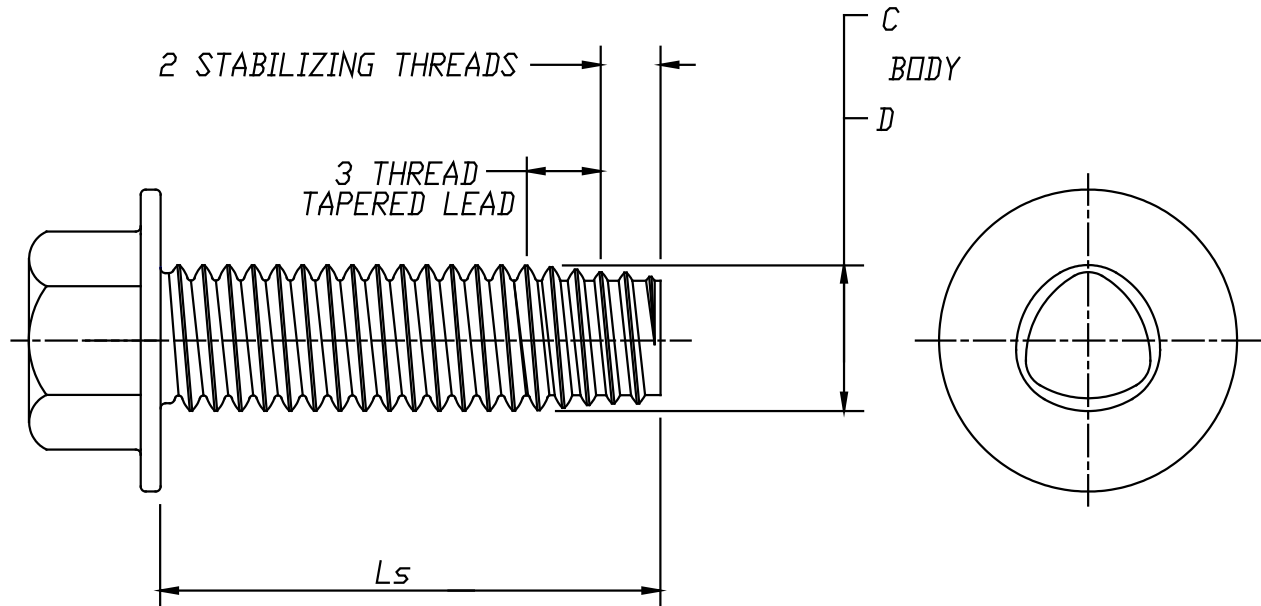

SIZE	PITCH	LIMITS	C	D
MP6	1.00	Max	6.10	6.00
		Min	5.97	5.85
MP8	1.25	Max	8.13	8.00
		Min	7.97	7.81
MP10	1.50	Max	10.15	10.00
		Min	9.97	9.78
MP12	1.75	Max	12.18	12.00
		Min	11.97	11.75
MP14	2.00	Max	14.20	14.00
		Min	13.97	13.72
MP16	2.00	Max	16.20	16.00
		Min	15.97	15.72

Notes: Ls = Screw length ordered.
 Tolerance per customer requirements or licensee practice.
 Dimensions shown are before plate.

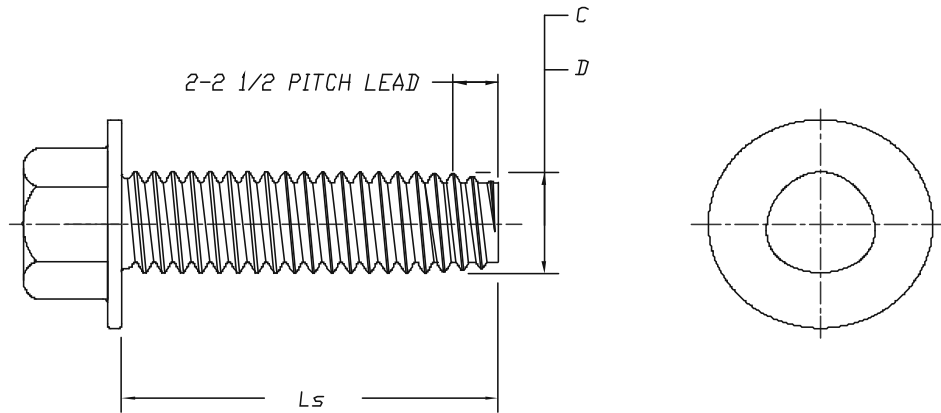

SIZE	PITCH	C	D	LIMITS	SIZE	PITCH	C	D
MP1.0	0.25	1.000	0.975	Max	MP4.0	0.70	4.02	3.95
		0.955	0.924	Min			3.92	3.83
MP1.2	0.25	1.200	1.175	Max	MP4.5	0.75	4.52	4.45
		1.155	1.124	Min			4.41	4.32
MP1.4	0.30	1.405	1.375	Max	MP5.0	0.80	5.02	4.94
		1.355	1.317	Min			4.91	4.81
MP1.6	0.35	1.61	1.58	Max	MP6.0	1.00	6.10	6.00
		1.53	1.49	Min			5.97	5.85
MP1.8	0.35	1.81	1.78	Max	MP8.0	1.25	8.13	8.00
		1.73	1.69	Min			7.97	7.81
MP2.0	0.40	2.01	1.97	Max	MP10.0	1.50	10.15	10.00
		1.93	1.88	Min			9.97	9.78
MP2.2	0.45	2.21	2.17	Max	MP12.0	1.75	12.18	12.00
		2.12	2.06	Min			11.97	11.75
MP2.5	0.45	2.52	2.48	Max	MP14.0	2.00	14.20	14.00
		2.43	2.37	Min			13.97	13.72
MP3.0	0.50	3.02	2.97	Max	MP16.0	2.00	16.20	16.00
		2.93	2.87	Min			15.97	15.72
MP3.5	0.60	3.52	3.46	Max				
		3.42	3.35	Min				

Notes: Ls = Screw length ordered.
Tolerance per customer requirements or licensee practice.
Dimensions shown are before plate.

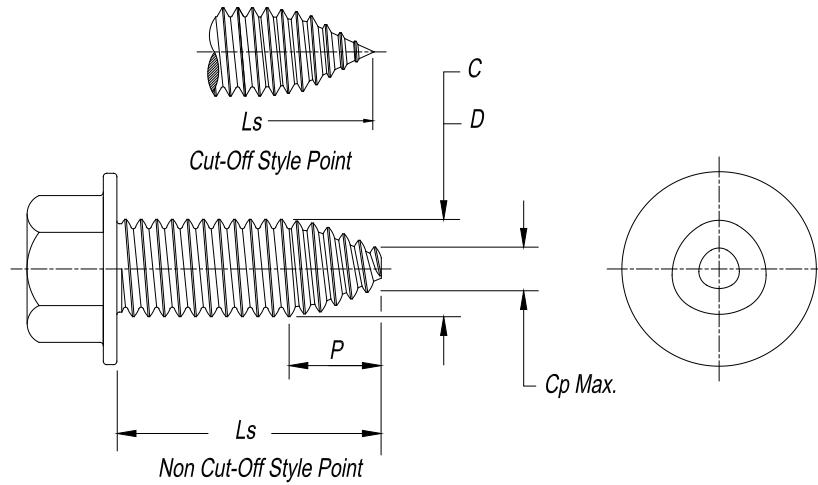

SIZE	PITCH	C	D	Cp Max	P Ref.	LIMITS	SIZE	PITCH	C	D	Cp Max	P Ref.
MP1.0	0.25	1.000	0.975	0.15	1.38	Max	MP3.5	0.60	3.52	3.46	1.47	3.30
		0.955	0.924			Min			3.42	3.35		
MP1.2	0.25	1.200	1.175	0.35	1.38	Max	MP4.0	0.70	4.02	3.95	1.63	3.85
		1.155	1.124			Min			3.92	3.83		
MP1.4	0.30	1.405	1.375	0.38	1.65	Max	MP4.5	0.75	4.52	4.45	1.96	4.13
		1.355	1.318			Min			4.41	4.32		
MP1.6	0.35	1.61	1.58	0.41	1.93	Max	MP5.0	0.80	5.02	4.94	2.29	4.40
		1.53	1.49			Min			4.91	4.81		
MP1.8	0.35	1.81	1.78	0.61	1.93	Max	MP6.0	1.00	6.10	6.00	2.62	5.50
		1.73	1.69			Min			5.97	5.85		
MP2.0	0.40	2.01	1.97	0.64	2.20	Max	MP8.0	1.25	8.13	8.01	3.86	6.88
		1.93	1.88			Min			7.97	7.81		
MP2.2	0.45	2.21	2.17	0.67	2.48	Max	MP10.0	1.50	10.15	10.00	5.03	8.25
		2.12	2.06			Min			9.97	9.78		
MP2.5	0.45	2.52	2.48	0.98	2.48	Max	MP12.0	1.75	12.18	12.00	6.20	9.63
		2.43	2.37			Min			11.97	11.75		
MP3.0	0.50	3.02	2.97	1.31	2.75	Max						
		2.93	2.87			Min						

Section 1: SCOPE

1.01 This section specifies the requirements for case hardened and tempered TAPTITE PRO® screws intended to be used in steel with a hardness up to 250HV. The requirements stated are intended to qualify TAPTITE PRO® screws as meeting their intended requirements and are not associated with specific applications.

1.02 REFERENCES:

ISO-898/1 Mechanical Properties
ISO-6507 Hardness Test – Vickers Test

Section 2: MATERIALS

2.01 Cold heading quality fully killed steel wire. Material shall conform to the following check analysis chemical composition limits.

Carbon	0.13 – 0.30
Manganese	0.54 – 1.81
Sulfur	0.045 Maximum
Phosphorous	0.035 Maximum
Silicon	0.10 Maximum
Boron	0.0005 – 0.002 (Optional)

Section 3: MECHANICAL PROPERTIES**3.01** Heat Treatment

Screws shall be heat treated in a gas carburizing or carbonitriding system, quenched in suitable media to create a martensitic microstructure. Minimum tempering temperature shall be 340°C minimum.

Case Hardness:	HV 280 – HV 370
Surface Hardness:	HV 450 minimum
Case Depth:	MP2 – 3.5 0.05mm – 0.18mm
	MP4 – 5.0 0.10mm – 0.23mm

Note: Case depth standards vary depending on applicable local standards. Case depths listed in this standard can be superseded by applicable local standards.

3.02 Torsional Strength Test**Minimum Torsional Strength (Torque in Nm)**

MP1.0	0.06
MP2.0	0.60
MP2.5	1.20
MP3.0	2.20
MP3.5	3.50
MP4.0	5.20
MP4.5	7.50
MP5.0	10.50

3.03 Ductility

Screws should withstand a wedge angle of 7° without head separating from shank.

3.04 Thread Forming Capability

Screws shall form a mating thread in specified steel test plates and screw thread shall display no signs of deformation. The internal thread formed shall be capable of accepting a standard 6g tolerance machine screw.

3.05 Hydrogen Embrittlement Test

Screws with electroplated finishes must withstand being in a tightened state for 24 hours and then withstand a retightening.

Section 4: TEST METHODS**4.03** Core Hardness

Core hardness shall be determined at the mid-radius of a transverse section through the screw taken at a distance sufficiently behind the point of the screw to be through the full minor diameter. The test shall comply with ISO 6507.

4.04 Case Hardness Test

For routine quality control purposes (where case depth and geometry of screws permit), case hardness may be measured on end, shank or head using Vickers Hardness procedure in accordance with ISO-6507. Hardness tests shall be made on plain finish or plated screws after the finish has been removed.

As an alternate method or for referee purposes a micro-hardness instrument can be used. In such cases, measurements shall be made on the thread profile of a properly prepared longitudinal metallographic specimen.

4.05 Case Depth Test

Case depth shall be measured at midpoint between crest and root on the thread flank using industry accepted methods.

4.06 Torsional Strength Test

The screw shall be clamped in place using a threaded or non-threaded clamping device so that clamped threads are not damaged. Three threads as a minimum must protrude beyond the top of the clamping device. Using a torque measuring device, torque shall be applied until the screw fractures. The torque required to cause fracture is the torsional strength. Fracture must occur in the exposed threads and not in the clamped portion.

On case hardened screws, sizes M5 and smaller, torsional strength testing is required in lieu of tensile testing.

4.07 Ductility Test

The sample screw shall be inserted into a hole in a hardened, 7° angle wedge block, having a hole size 0.5 to 1.0mm larger than the nominal screw size. An axial compressive load shall be applied against the top of the screw until the plane of the underhead bearing surface is bent permanently to 7° with respect to a plane normal to the axis of the screw.

It is acceptable to induce the 7° permanent deformation using a hand-held hammer.

4.06 Thread Forming Capability Test

Sample screws shall be driven into holes in specified steel test plates until an internal thread of full major diameter is formed completely through the full thickness of the test plate. The driving speed shall not exceed 300rpm. Recording the maximum torque required to form the internal thread is optional. The use of a lubricant on the screw is permissible.

(i) *Test Plate for thread capability test and hydrogen embrittlement test.*

Test plate shall be of low carbon steel having a hardness range of 115 to 150 HV30. Test holes shall be drilled or punched and reamed to a tolerance of plus or minus 0.025mm of hole size listed below.

Table 1

Nominal Screw Size & Plate Thickness		1.0	2.0	2.5	3.0	3.5	4.0	4.5	5.0
Hole Diameter	Max	0.900	1.825	2.275	2.775	3.200	3.680	4.400	4.590
	Min	0.880	1.800	2.250	2.750	3.170	3.650	4.100	4.560
NOTE: Plate thickness tolerance in accordance with ISO 5954 (For Rolled Plate)									

4.07 Hydrogen Embrittlement

Screws with electroplated finishes shall be baked for a minimum of one hour within the temperature range of 190 – 230°C as soon as practicable after plating to avoid hydrogen embrittlement.

Electroplated screws shall be installed into the hydrogen embrittlement test plates as specified in Table 1. Seat the head of the screw against a hardened steel flat washer or split lock washer. If the screws are not threaded to the head, additional washers and/or spacers (hardened or unhardened) shall be used under the bearing washer to provide a minimum stack thickness corresponding to the length of the maximum unthreaded length on screw plus the distance equal to two to three thread pitches. Full form screw threads must be engaged through the test plate's thickness. Screws shall be tightened to a test torque equal to 80% of the average failure torque of five screws driven into the test plate until they break into two pieces. The screws shall remain in the tightened state for a minimum of 24 hours, after which all screws will be retightened to the original test torque. The lot is acceptable if no screws break during the waiting period or during retightening.

Test Plate Options: Screws can be hydrogen embrittlement tested in their original thread capability test plates or in previously threaded, previously used test plates.

Section 1: SCOPE

1.01 This section specifies the requirements for CORFLEX®-'I' induction hardened TAPTITE PRO® screws, intended to be used in steel with a hardness up to 250HV. The requirements stated are intended to qualify CORFLEX®-'I' TAPTITE PRO® screws as meeting their intended requirements and are not associated with any specific applications.

1.02 REFERENCES:

ISO-6507 Vickers Hardness Testing Procedure

ISO-898/1 Mechanical Properties with the following exceptions

- (i.) Screws produced to this standard possess mechanical properties in line with ISO 898/1 property classes 8.8, 9.8 and 10.9.
- (ii.) Decarburization on CORFLEX®-'I'™ TAPTITE PRO® thread rolling screws seriously impairs the thread forming properties of the screw and is therefore not permitted. Decarburization as permitted by ISO 898/1 is replaced in this standard by a requirement for carbon restoration.

Section 2: MATERIAL

Screws shall be made from cold heading quality, aluminum killed, fine grained, spheroidized annealed steel wire. Material shall meet the chemical composition limits for the property class ordered, per ISO-898-1.

AISI C4037 material has been the REMINC/CONTI recommended material grade. Other materials meeting the material requirements specified in ISO 898, part 1 are also acceptable.

Material must be capable of meeting all requirements specified for the induction hardened point.

However, the specific condition of the rods and wire as to mechanical qualities, temper, state of anneal, surface finish, etc. shall be in accordance with appropriate practices established for optimum heading and other manufacturing requirements.

2.01 Heat treatment

Screws are to be neutral (through) hardened in a continuous non-carbonizing furnace using fine grain practices. Furnace atmosphere must be controlled to maintain decarburization restrictions as specified in Section 3.3.

Quenching medium to suit selected material, suitable to create a martensitic microstructure.

Minimum tempering temperatures relative to grade strength (8.8, 9.8, 10.9) should follow that specified in ISO 898/1.

Section 3: MECHANICAL PROPERTIES**3.01** Wedge Tensile

Screws shall meet wedge tensile breaking loads as specified in ISO-898/1 for the applicable equivalent property class (8.8, 9.8, 10.9).

Screws not having suitable head styles (i.e. countersunk heads) are exempt from this test. Screws with lengths shorter than 13mm have a length less than or three times the nominal screw diameter are also exempt.

3.02 Decarburization

During the hardening process the carbon potential of the atmosphere shall be maintained at a level between “zero” (0) decarburization to slightly in excess of the carbon content of the screws being processed. This process of carbon restoration is designed to eliminate partial and total decarburization of the screw thread form. Partial or complete decarburization of the screw thread form would seriously impair the thread rolling properties of the screw.

Carbon enrichment up to 0.1mm maximum from the surface of the screw is permitted as a result of the carbon restoration process.

3.03 Surface Hardness

The surface hardness shall not be more than 30 Vickers points above the measured core hardness on the product when readings of both surface and core are carried out.

3.04 Thread Forming Capability

Screws shall form a mating thread in specified steel test plates and screw thread shall display no signs of thread deformation. The internal thread formed shall be capable of accepting a standard 6g tolerance machine screw.

3.05 Point Hardness

The lead threads shall be induction hardened to achieve minimum hardness of HV 450, including one to three full threads to a depth of 0.2mm below the root as shown in Figure 1.

Minimum Hardness (RC48/Vickers 484) must be held from the minimum depth of penetration to the crest of the thread throughout the induction pattern.

Following induction hardening, screws shall be stress relieved to 200 – 230°C.

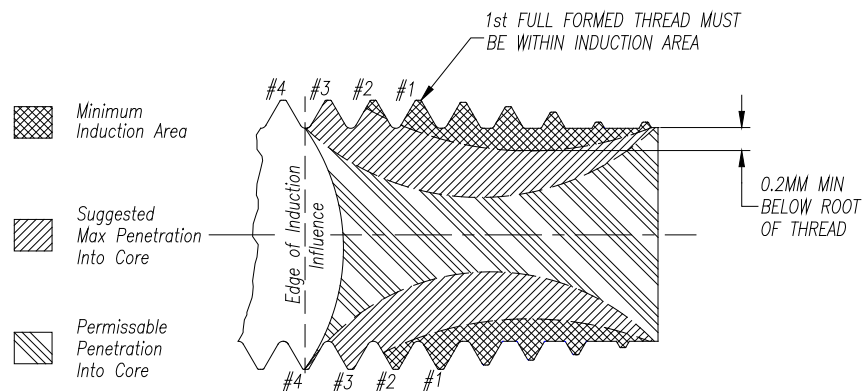

Figure 1. Induction Hardened Zone (pictorial representation)

Section 4: TEST METHODS**4.01** Decarburization

Longitudinal sections shall be taken through the thread axis approximately one nominal diameter from the end of the screw. The specimen shall be suitably mounted and prepared for metallographic examination at not less than 100 x magnification. Prior to examination the sample shall be etched in a Nital solution.

4.02 Surface Hardness Test

The surface hardness shall be measured using the Vickers Hardness Testing Procedure in accordance with ISO 6507.

The surface hardness shall be performed on the head after removal of any finish and suitable preparation (1200 grit grinding or better). Care should be taken to remove as little material as possible.

For referee purposes, a micro-hardness instrument with a Vickers indenter and a 300g load shall be used. In such cases, measurements shall be made on the thread profile of a suitably prepared longitudinal metallographic specimen.

4.03 Thread Forming Capability Test

Sample screws shall be driven into holes in specified test plates until an internal thread of full major diameter is formed completely through the full thickness of the test plate. Speed of driving shall not exceed 300 RPM. Recording the maximum torque required to form the thread is optional. The use of a lubricant on the screw is permissible.

(i) *Test Plate for thread capability test.*

Test plate shall be of low carbon steel having a hardness range of 115 to 150 HV30. Test holes shall be drilled or punched, and reamed to a tolerance of plus or minus 0.025mm of hole size listed below.

Table 2

Nominal Screw Size & Plate Thickness		6.0	8.0	10.0	12.0	14.0	16.0
Hole Diameter	Max	5.530	7.436	9.336	11.243	13.143	15.143
	Min	5.500	7.400	9.300	11.200	13.100	15.100
NOTE: Plate thickness tolerance in accordance with ISO 5954 (For Rolled Plate)							

4.04 Induction Hardening Test

The hardness of the induction hardened zone may for routine control purposes be carried out on the screw end using a Vickers 5kg load. As an alternative or where this method is not applicable, a Vickers micro-hardness test with a 300g load may be used on a suitably mounted and prepared specimen. This method shall be a referee in case of dispute.

The extent of the induction hardened zone shall be determined by visual examination of a longitudinal section taken through the induction hardened portion and etched in accordance with standard metallurgical practice (See Figure 1).

Section 5: MARKING**5.01** Symbols

In order to identify CORFLEX®-'I' screws as equivalent property class but not the same as a through hardened metric machine screw, markings must be different than metric machine screws.

Marking is obligatory for hex, hex flange and hex washer head screws and other head styles where the shape permits.

Equivalent Property Class	8.8	9.8	10.9
CORFLEX®-'I' TAPTITE PRO® Head Marking	08	09	010

5.02 Trade (Identification) marks

The trade (identification) marks of the manufacturer is mandatory on all products, which can be marked with manufacturers' symbol.

Section 6: SURFACE DISCONTINUITIES

- 6.01** The application of surface discontinuity specifications is per agreement between manufacturer and end user customer. Regardless of the agreed upon specification, spec parameters should not be applicable to point threads and thread forming threads.

Section 7: EMBRITTLEMENT

The issue of embrittlement is relative to the property class and finish/coating ordered and is to be determined by agreement between manufacturer and end user customer.

Section 1: SCOPE

This section specifies the requirements for CORFLEX®-‘N’ “neutral” hardened TAPTITE PRO® and TAPTITE PRO® “SP”™ screws, intended for use in soft metals such as aluminum, zinc and magnesium. The requirements stated are intended to qualify CORFLEX®-‘N’ TAPTITE PRO® screws as meeting their intended requirements and are not associated with any specific applications.

1.01 REFERENCES:

ISO-898/1 Mechanical Properties with the following exceptions

- (i.) Screws produced to this standard possess mechanical properties in line with ISO 898/1 property classes 8.8, 9.8 and 10.9.
- (ii.) Decarburization on CORFLEX®-‘N’ heat treated TAPTITE PRO® and TAPTITE PRO® “SP”™ thread rolling screws can seriously impair the thread forming properties of the screw and is therefore not permitted. Decarburization as permitted by ISO 898/1 is replaced in this standard by a requirement for carbon restoration.

Section 2: MATERIAL

Cold heading quality fully killed carbon steel, fine grain, spheroidize annealed.

Carbon steel with additives i.e. boron, manganese or chrome can be used. Steel to conform to ISO-898/1.

Carbon Steel - Check analysis composition - % by weight	
Carbon	0.25 – 0.55
Phosphorous	0.035 Maximum
Sulfur	0.035 Maximum

Carbon Steel with Additives - % by weight	
Carbon	0.15 – 0.40
Phosphorous	0.035 Maximum
Sulfur	0.035 Maximum

In the case of boron alloyed steel with a carbon content below 0.25%, the minimum manganese content shall be 0.60%.

2.01 Heat Treatment

Screws are to be neutral (through) hardened in a continuous non-carburizing furnace using fine grain practices. Furnace atmosphere must be controlled to maintain decarburization restrictions as specified in Section 3.2 and surface hardness conditions as specified in Section 3.3.

Quenching medium to suit selected material, suitable to create a martensitic microstructure.

Minimum tempering temperatures relative to grade strength (8.8, 9.8, 10.9) should follow that specified in ISO 898/1.

Section 3: MECHANICAL PROPERTIES**3.01** Wedge Tensile

Screws shall meet wedge tensile breaking loads as specified in ISO-898/1 for the applicable equivalent property class (8.8, 9.8, 10.9).

Screws not having suitable head styles (i.e. countersunk heads) are exempt from this test. Screws with lengths shorter than 13mm have a length less than or three times the nominal screw diameter are also exempt.

3.02 Decarburization

During the hardening process the carbon potential of the atmosphere shall be maintained at a level between “zero” (0) decarburization to slightly in excess of the carbon content of the screws being processed. This process of carbon restoration is designed to eliminate partial and total decarburization of the screw thread form. Partial or complete decarburization of the screw thread form would seriously impair the thread rolling properties of the screw.

Carbon enrichment up to 0.1mm maximum from the surface of the screw is permitted as a result of the carbon restoration process.

3.03 Surface Hardness

The surface hardness shall not be more than 30 Vickers points above the measured core hardness on the product when readings of both surface and core are carried out.

3.04 Thread Forming Capability

Screws shall form a mating thread in specified aluminum test plates and screw thread shall display no signs of thread deformation. The internal thread formed shall be capable of accepting a standard 6g tolerance machine screw.

Section 4: TEST METHODS**4.01** Decarburization

Longitudinal sections shall be taken through the thread axis approximately one nominal diameter from the end of the screw. The specimen shall be suitably mounted and prepared for metallographic examination at not less than 100 x magnification. Prior to examination the sample shall be etched in Nital solution.

4.02 Surface Hardness Test

The surface hardness shall be measured using the Vickers Hardness Testing Procedure in accordance with ISO 6507.

The surface hardness shall be performed on the head after removal of any finish and suitable preparation (1200 grit grinding or better). Care should be taken to remove as little material as possible.

For referee purposes, a micro-hardness instrument with a Vickers indenter and a 300g load shall be used. In such cases, measurements shall be made on the thread profile of a suitably prepared longitudinal metallographic specimen.

4.03 Thread Forming Capability Test

Sample screws shall be driven into holes in specified test plates until an internal thread of full major diameter is formed completely through the full thickness of the test plate. Speed of driving shall not

exceed 300 RPM. Recording the maximum torque required to form the thread is optional. The use of a lubricant on the screw is permissible and may be required to avoid galling.

(i) *Test Plate for thread capability test.*

Test plate shall be aluminum with a hardness range of HB30 - 75. Test holes shall be drilled. A mating thread must be formed by driving sample screw into the test plate until a minimum of one full thread extends beyond the test plate

Nominal Thread Size (mm)	5	6	8	10	12	14	16	
Plate Thickness (mm)	10	12	16	20	24	28	32	
Hole Size (mm)	Min	4.61	5.51	7.39	9.27	11.15	13.03	15.03
	Max	4.66	5.58	7.47	9.37	11.26	13.16	15.16

Section 5: MARKING

5.01 Symbols

In order to identify CORFLEX®-‘N’ screws as equivalent property class but not the same as a through hardened metric machine screw, markings must be different than metric machine screws.

Marking is obligatory for hex, hex flange and hex washer head screws and other head styles where the shape permits.

Equivalent Property Class	8.8	9.8	10.9
CORFLEX®-‘N’ TAPTITE PRO® Head Marking	8N	9N	10N

5.02 Trade (Identification) marks

The trade (identification) marks of the manufacturer is mandatory on all products, which can be marked with manufacturers’ symbol.

Section 6: SURFACE DISCONTINUITIES

6.01

The application of surface discontinuity specifications is per agreement between manufacturer and end user customer. Regardless of the agreed upon specification, spec parameters should not be applicable to point threads and thread forming threads.

Section 7: EMBRITTLEMENT

The issue of embrittlement is relative to the property class and finish/coating ordered and is to be determined by agreement between manufacturer and end user customer.